

SERIES	PRODUCT FAMILY	VERSION	MODEL
900	GRILL	GAS	NEGL92T

DESCRIPTION

LAVA ROCK GAS GRILL 40 CM TOP VERSION



TECHNICAL DATA:

STRUCTURE	TOP	NR. COOKING ZONES	1
WIDTH	400 mm	GRILL DIMENSIONS	380x645 mm
DEPHT	900 mm		
HEIGHT	320 mm		
NET WEIGHT	61 kg		
VOLUME	0.2 m3		
GAS POWER	12.5 kW		

SERIES	PRODUCT FAMILY	VERSION	MODEL
900	GRILL	GAS	NEGL92T

FEATURES:

Gas Lava rock Grill, top version. Stainless steel top (AISI 304) thickness 20/10, pre-fitted for head-to-head connection. One cooking zone heated by means of steel burners and stabilized flame incl. pilot burner and safety thermocouple. Gas supply by safety valve tap. The cooking grid can be positioned on two levels to optimize grilling. Removable grease tray for easy cleaning. Meat grid included. Height-adjustable feet.

OPTIONAL ACCESSORIES:

• Kit 6 KG PACKAGE OF LAVA ROCKS

ERL

SERIES	PRODUCT FAMILY	VERSION	MODEL
900	GRILL	GAS	NEGL92T

INSTALLATION SCHEME

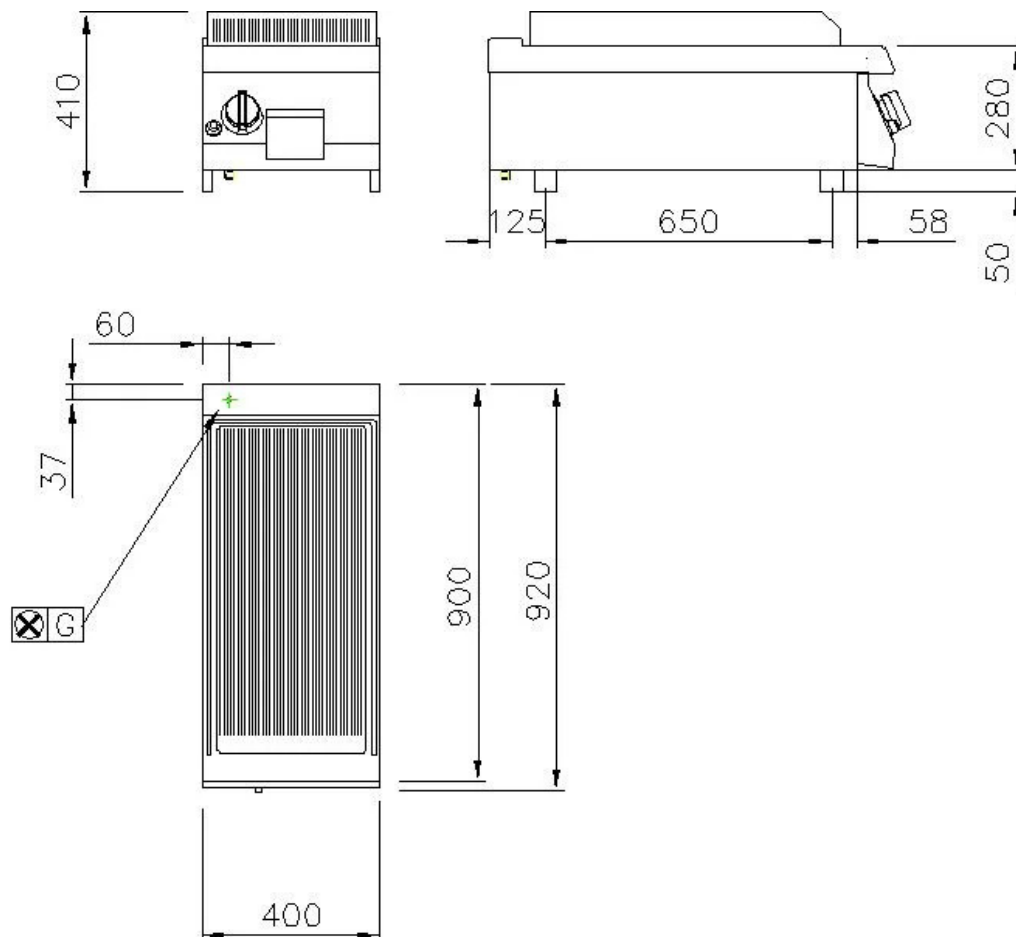

	E1	SOCKET
	AF	COLD WATER
	AC	HOT WATER
	G	GAS
	S	DRAINING

Ø 1/2" 600 mm

NOTES FOR THE INSTALLER:

All water and gas connections must be fitted with a shut-off valve or ball valve. Main gas connections must be provided of closing gate device.

Gas connections must not use welded tubes.

Gas connections must be jacketed according to current rules in the country.

Electric connections must be provided of safety switch and a minimum exit wire of 1,5 meter lenght (except where otherwise required in the drawing).

All sockets must be built according to safety-rules in force. Suited for humid room and settled with necessary plug. All electric connections must be provided of main switch.

The specification shown in this document are to be considered not bounding.

The company reserves the right to make technical changes at any moment.